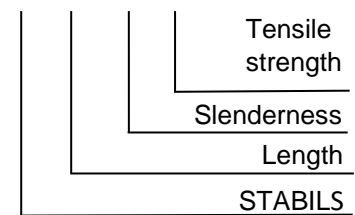

Technical Data Sheet
SB 60/70 - 2000

With the high-strength, straight steel fiber, the pull-out resistance is achieved by means of positive locking between the steel fiber and the concrete. This means that the force transmission in the crack is less dependent on the pull-out distance than with conventional steel fibers with frictional locking.

The specifically produced anchor nodes can be varied in number, shape, size and position according to the field of application. There are also advantages in terms of fiber distribution and fresh concrete workability, which allow a higher maximum content of steel fibers.

Fiber designation
SB 60/70 - 2000

Geometry and material properties

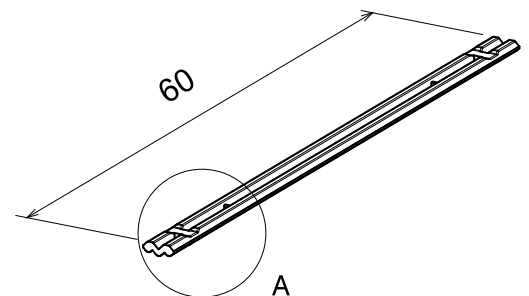
Fiber length (L)	60,0 mm (+/- 5 %)
Equivalent diameter (d)	0,86 mm (+/- 5%)
Slenderness ratio (L/d)	70 (+/- 7,5 %)
Tensile strength (R _m)	2.000 MPa
Residual expansion	min. 5 %
Young`s modulus (E)	210.000 MPa
Material number	1.1211
Number of anchor knots	4
Number of steel fibers per kg	approx. 3.600 pieces
Minimum dosage DIN EN 14889-1	15 kg/m ³

SB 60/70 - 2000

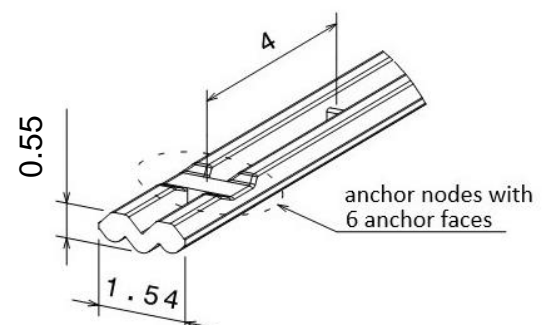
Packaging

Environmentally friendly cartons	
Filling weight /box	20 kg
Cartons/pallet	30 pieces
Weight/pallet	600 kg
Delivery also possible as big bag	approx. 600 kg

SB 60/70 - 2000 detail view

Product certification

The steel fibers described are compliant with the following standards:

EN 14889-1 Group 2 (steel fibers from strip steel)