

# STABILS

PERFORMANCE FOR CONCRETE

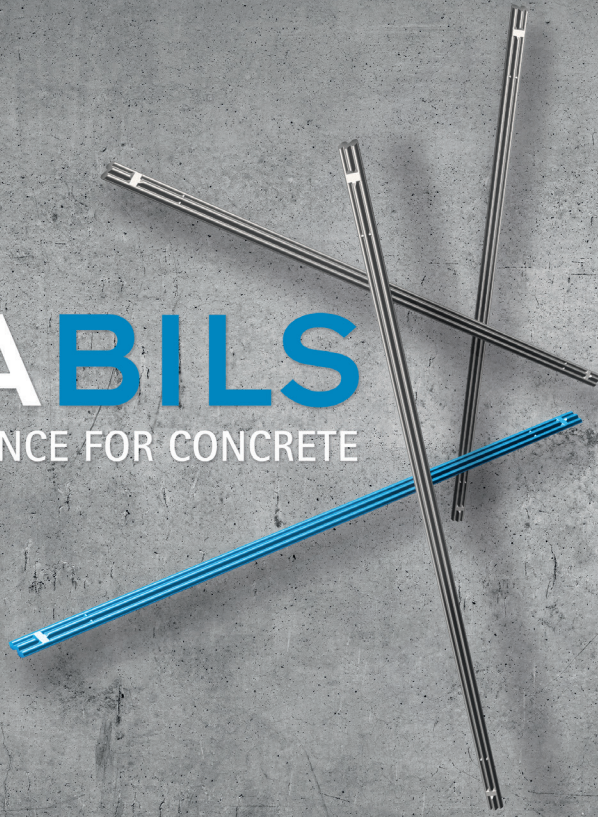

The steel fiber for efficient  
concrete elements

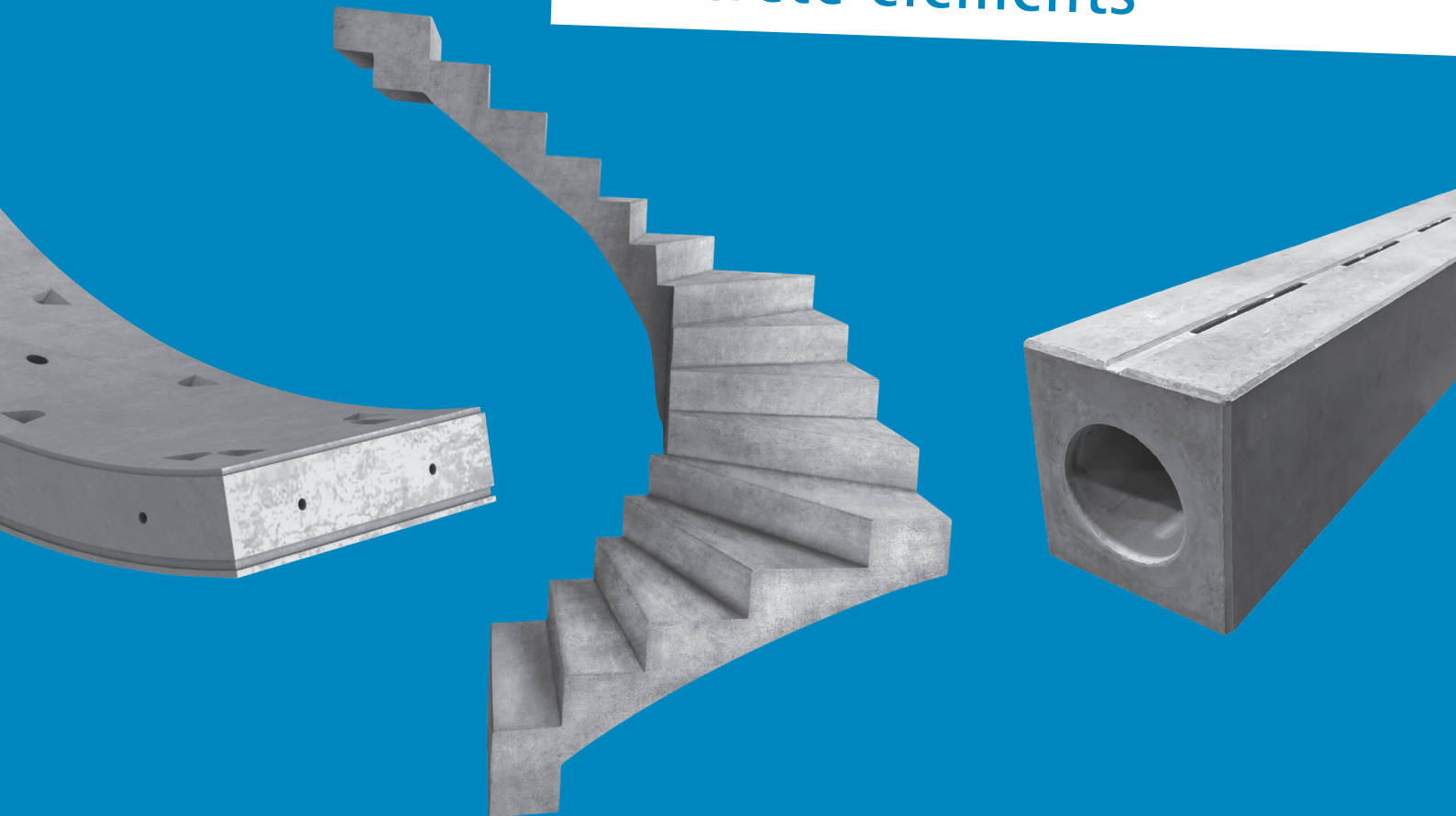

# STABILIS

## Straight steel fiber with optimum properties

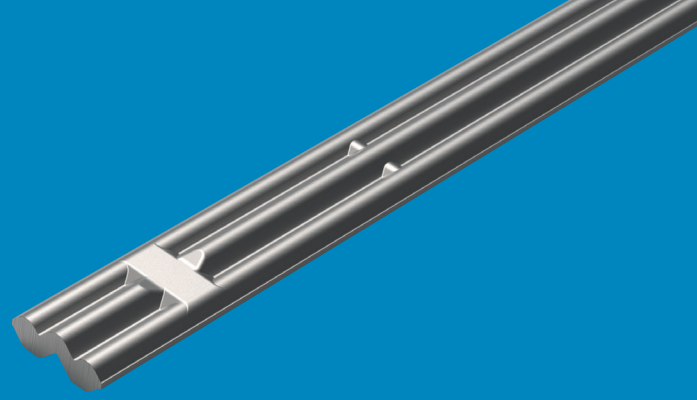

### Optimize your concrete elements

The choice of reinforcement has a major influence on the quality, load-bearing capacity and durability of a concrete structure. The ductility and limitation of cracks are also significantly influenced. Compared to conventional reinforcing steel, steel fiber reinforcement offers the following advantages:

#### Durable precast concrete elements with a better CO<sub>2</sub> footprint

- More homogeneous fiber distribution in the concrete element
- Excellent post-cracking strength with lower fiber dosage
- Increased durability and sustainability for concrete elements
- Increased life cycle of a concrete structure

#### Lower costs and practical construction advantages

- Good workability of fresh concrete
- Time-saving thanks to simpler planning and faster construction
- Cost reduction thanks to less material required and personnel expenses
- Better safety thanks to less risk of injury
- No fiber balling even with higher dosages
- Best pumpability



ECONOMICAL



CO<sub>2</sub> REDUCING



ECOLOGICAL  
SUSTAINABLE



HIGH TENSILE  
STRENGTH



LONG LIFETIME



VERSATILE  
APPLICABLE

Taking all these factors into account, STABILIS steel fibers offer an efficient and economical solution.

Test our products or find out more about our service.

## Cost-efficient, safe and durable reinforcement for precast concrete elements

- Simple and precise dosing
- Increased productivity

STABILS steel fibers are also very cost-effective. Less conventional reinforcing steel is required. In addition, less storage space is required for reinforcing steel.

High quality with less labor and less reinforcing steel guarantees a win-win situation. A standardized product requires suitable reinforcement.

## STABILS: hardened and tempered steel fibers for concrete reinforcement

The manufacture of quality products must not be at the expense of productivity. This is especially true for precast concrete elements. In order to offer their customers a durable and economical end product, manufacturers of precast concrete elements rely on the high-performance of STABILS steel fibers from BILSTEIN STEEL FIBER.

## STABILS: enables the combination of quality and productivity

Concrete produced with STABILS leads to minimization of cracks. In addition, precast manufacturers can be more productive with STABILS steel fibers, as conventional reinforcement is greatly reduced or completely replaced.

Concrete has inherently low tensile strength and ductility. These properties can be improved by adding reinforcement. Various standards and guidelines regulate the use of steel fibers as concrete reinforcement worldwide with following focuses:

- Minimizing or limiting the formation of cracks
- Improving ductility
- Increasing structural safety and serviceability

Tensile test on single steel fiber

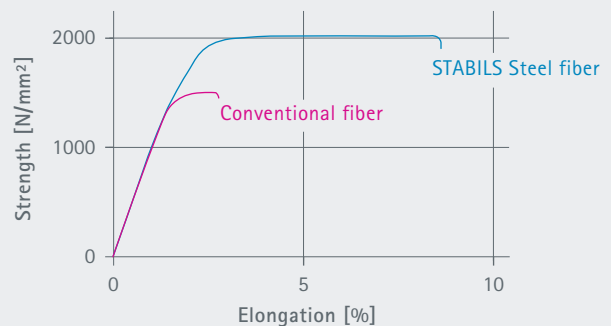

4-point bending test on beams according to DAfStb guideline „Steel fiber reinforced concrete“

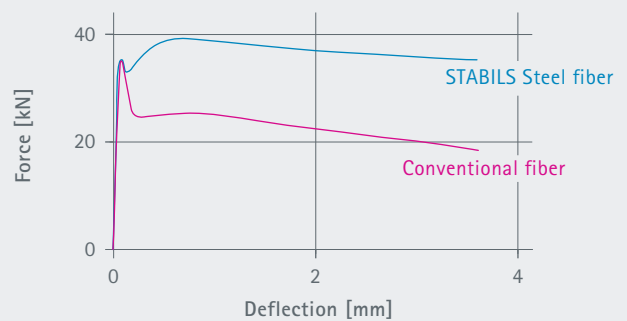

Characteristic post-cracking flexural strength as a function of fiber dosage according to DAfStb guideline „Steel fiber reinforced concrete“ (C 30/37)

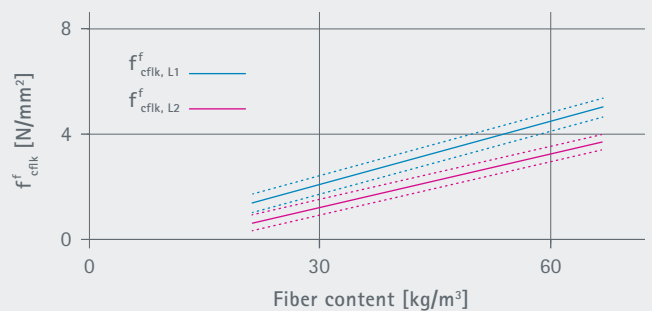

Characteristic post-cracking flexural strength as a function of fiber dosage according to DAfStb guideline „Steel fiber reinforced concrete“ (C 50/60)

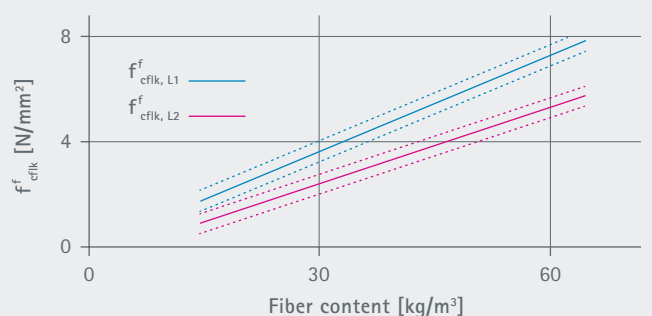

# Savings for a spiral precast stair through STABILS steel fiber

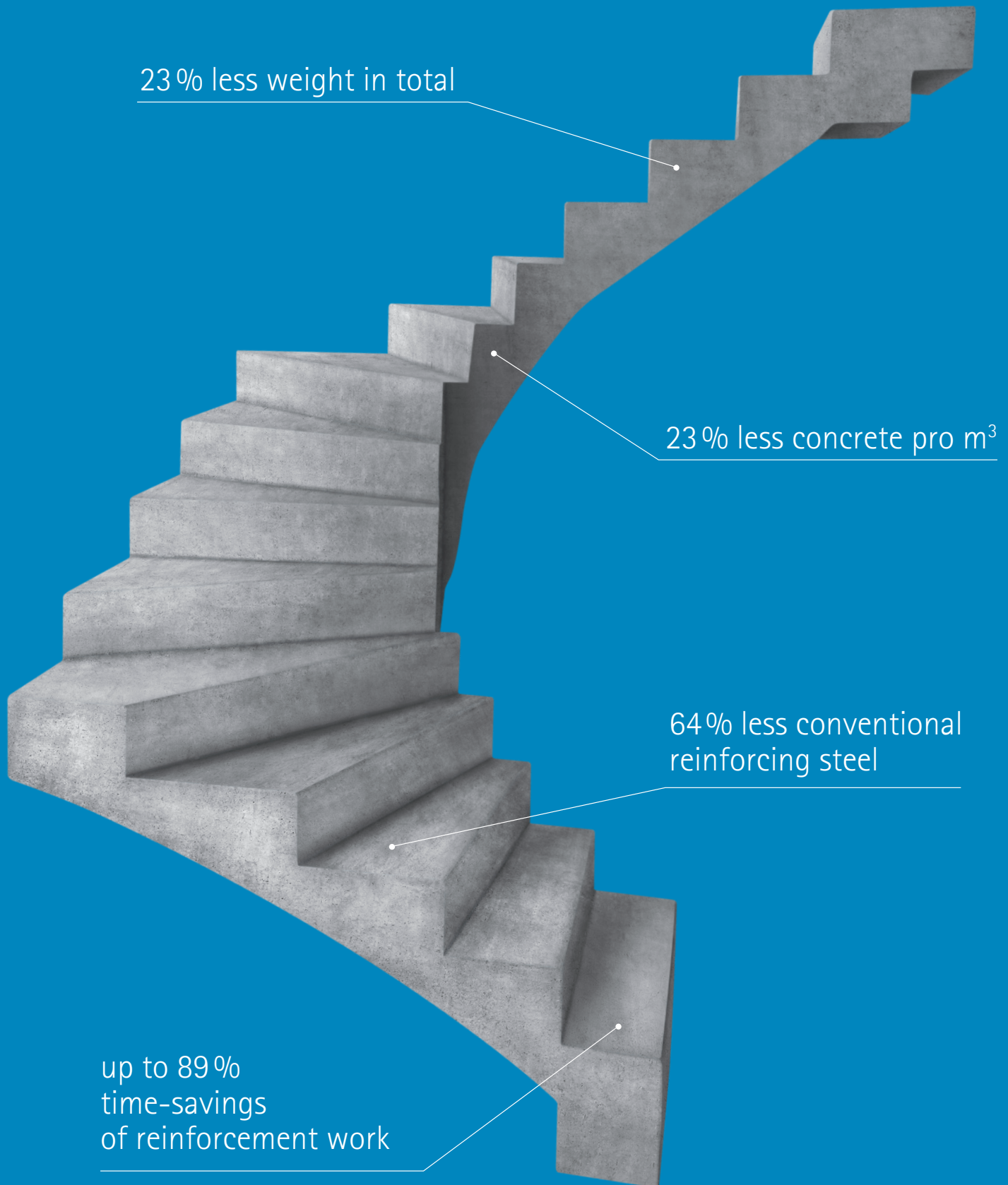

23% less weight in total

23% less concrete pro m<sup>3</sup>

64% less conventional reinforcing steel

up to 89%  
time-savings  
of reinforcement work

# Lower manufacturing costs with consistent performance

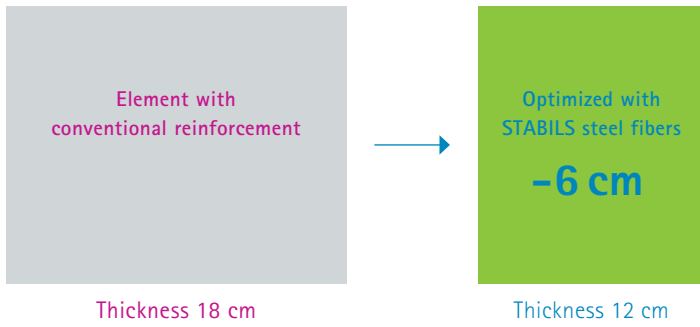

## CO<sub>2</sub> reduction

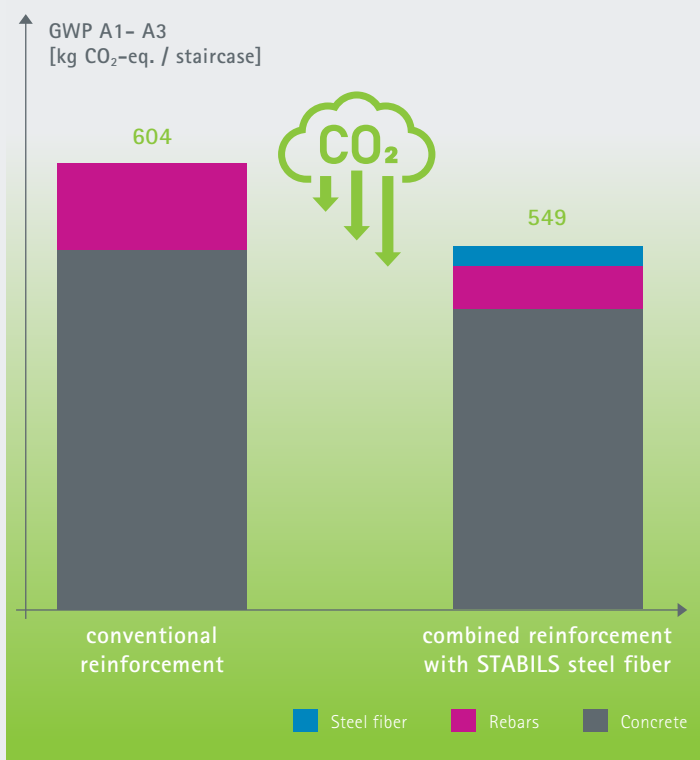

Taking all these factors into account, STABIS steel fibers offer an efficient and economical solution.

Test our products or find out more about our service.

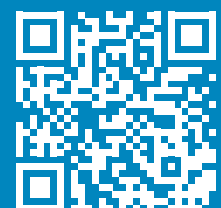

# STABILS

for strong precast concrete elements

The world of concrete has never offered so many creative possibilities. Steel fibers create a new quality of concrete reinforcement.

SB 50/58 – 2000

SB 60/70 – 2000



## Product features

- Made from cold-rolled strip
- Fiber length 50 mm and 60 mm
- Equivalent diameter 0.86 mm
- Tensile strength 2,000 MPa
- Elongation min. 5%
- STABILS steel fibers are CE certified

## How the STABILS fiber works

For STABILS steel fibers, the force is transmitted by means of sliding form lock between fiber and concrete over the entire pullout process.

The high elongation capacity of STABILS steel fibers with a very high tensile strength enables a high pull-out resistance without fiber breakage.

## Highest performance

STABILS steel fibers provide solutions over conventional reinforcement through the unique combination of a perfectly shaped anchor node and a material with extreme high tensile strength.

## Non-deformable anchor nodes

The anchor nodes of STABILS steel fibers are non-deformable and ensure perfect anchoring so that the fibers remain firmly in the concrete.

## STABILS creates a new quality standard of concrete reinforcement

STABILS is convincing proof that advanced technology has a decisive influence. Our technology increases efficiency and reduces costs.

The unique shape and geometry of the STABILS steel fiber offers an unprecedented level of anchorage, tensile strength and ductility, so that maximum performance is guaranteed.

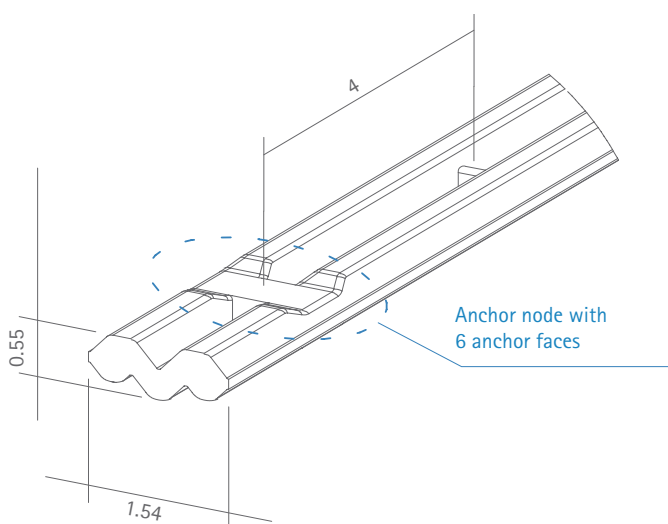
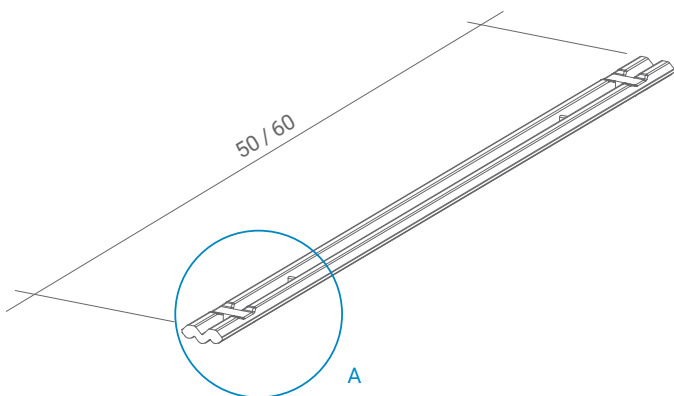



## BILSTEIN – renowned worldwide for cold-rolled strip

### BILSTEIN STEEL FIBER GmbH

With the straight and high-strength steel fiber STABIS, the BILSTEIN GROUP, the world's leading company for cold-rolled special steels, is setting a new benchmark for efficient concrete reinforcement and CO<sub>2</sub>-reduced precast concrete elements.

The core business of BILSTEIN STEEL FIBER GmbH is not only the production, but also the distribution and provision of services related to the innovative STABIS steel fiber.



### BILSTEIN GROUP

The STABIS steel fiber is the result of more than 112 years of competence of the BILSTEIN GROUP in the field of steel. The focus is on the fulfillment of demanding customer requirements, highest product quality and maximum sustainability.

The BILSTEIN GROUP is a global supplier of premium cold-rolled strip solutions.

By using the most innovative technologies, we are constantly breaking new ground. The opportunities for cooperation within the BILSTEIN GROUP network make us one of the strongest international partners for cold-rolled strip applications.

# STABILS service package

Our experts will be pleased to advise and support you in all phases of your project:

- ✓ Concrete technology consulting service
- ✓ Technical support from initial testing to practical application, from product manufacturing to construction site
- ✓ Solution approaches for evaluating the optimization of concrete elements

and in close cooperation with external specialists:

- ✓ Constructive optimization through structural design
- ✓ Preparation of technical test verifications
- ✓ Evaluation of economic efficiency and life cycle assessment
- ✓ Research projects in collaboration with renowned universities and colleges in Germany and abroad



[bilstein-steelfiber.de](https://bilstein-steelfiber.de)

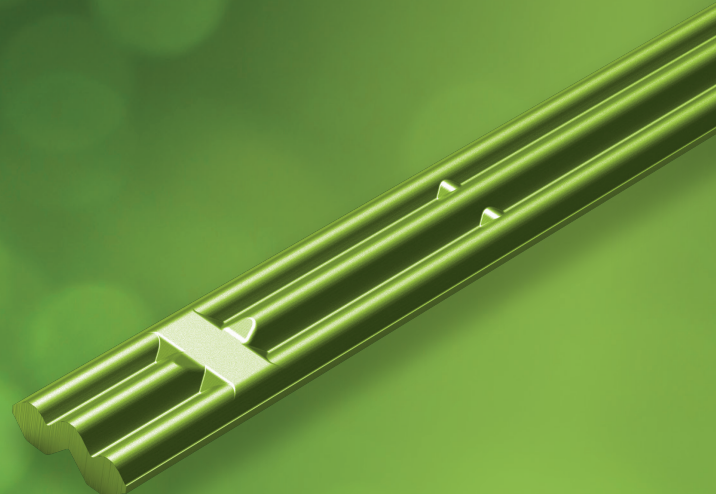

**BILSTEIN STEEL FIBER**

A BILSTEIN GROUP COMPANY

Im Weinhof 36, 58119 Hagen, Deutschland  
[stabils@bilstein-steelfiber.de](mailto:stabils@bilstein-steelfiber.de) | +49 2334 82-0